

Standard Coupling
(supplied with actuator
weight 0.07 lbs/0.03 kg)

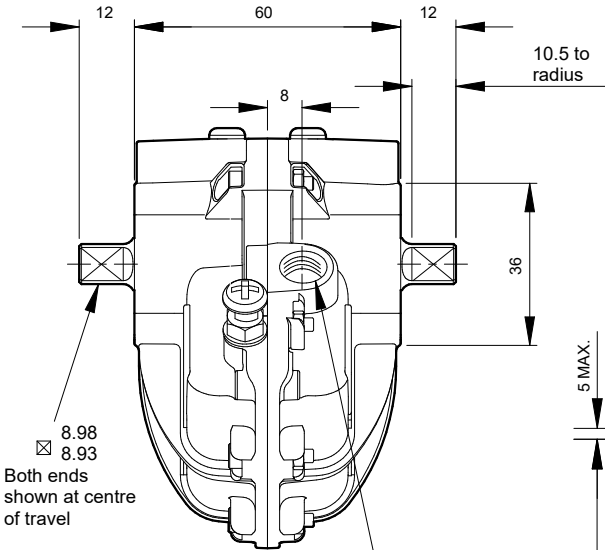

Both ends shown at centre of travel

2 Air ports staggered thread details below

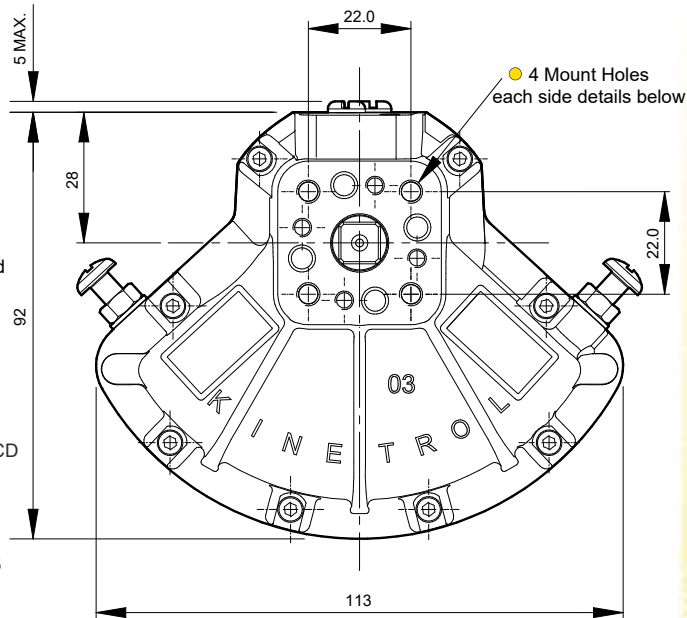

4 Mount Holes each side details below

Air Port/Mount Hole Details

Model	Air Ports	Mount Holes
034-100	G ¹ / ₈	4 x M5 x 10 deep on 31.1 PCD
037-100	1/8 NPT	4 x 10-24 UNC x 0.39" deep on 1.225" PCD

Visual Red Indicator supplied as standard - see page 3

Specification

Output Torque

220 lbf ins/25.3 Nm
at 100 psi/7 bar

Angle of Travel (adjustable)

80° - 100°
(restricted travel versions available)

Displaced Volume

3.66 in³/60 cm³

Finish

Epoxy stove enamel

Weight

1.53 lb/0.70 kg
(excluding coupling)

For further information see General Specification on page 5.

Options

- Fail safe spring return units - clockwise or counter clockwise see pages 27-29
- Limit switch boxes for open/close indication - various switches for hazardous areas see pages 31-34
- Integral solenoid valve see page 38
- Clear Cone position monitor see page 38
- 180° model see pages 51/52
- Female drive and mounting details to DIN 3337 and ISO 5211 see pages 57/58
- ISO adaptor see page 26
- Code identification see page 30
- Torque outputs see pages 6-8
- See pages 57-60 for English dimensions and dimensions of spring options
- High temperature/Low temperature options see page 5

