

Model 14

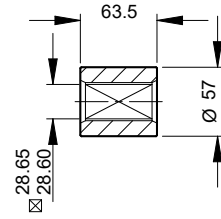

Standard Coupling
(supplied with actuator
weight 1.5 lbs/0.7 kg)



Specification

Output Torque

12000 lbf ins/1375 Nm
at 100 psi/7 bar

Angle of Travel (adjustable)

80° - 100°
(restricted travel
versions available)

Displaced Volume

201 in³/3294 cm³

Finish

Epoxy stove enamel

Weight

29.5 lb/13.4 kg
(excluding coupling)

For further information
see General Specification
on page 5.

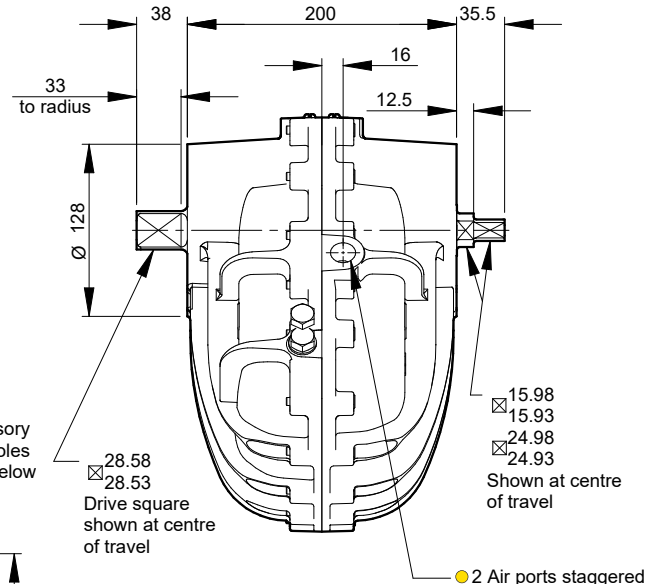
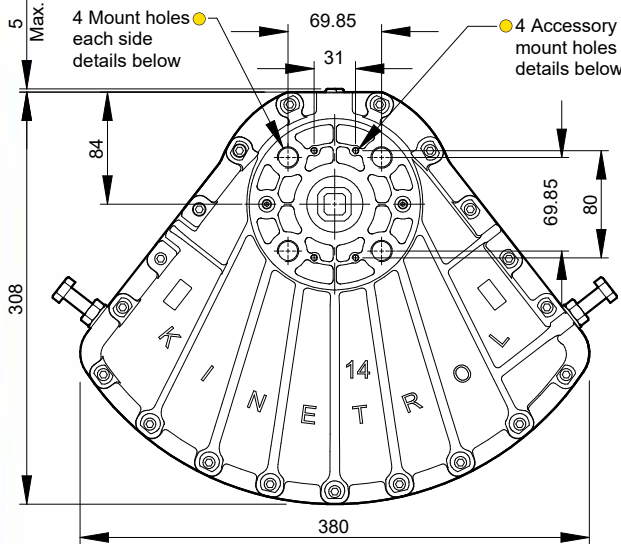

Air Port/Mount Hole Details

Model	Air Ports	Mount Holes & Accessory Mount Holes
144-100	G ¹ / ₂	4 x M16 x 28.5 deep on 98.8 PCD 4 x M5 x 10 deep
147-100	1/2 NPT	4 x 5/8 - 11 UNC x 1.12" deep on 3.89" PCD 4 x 10-24 x 3/8" deep

Visual Red Indicator supplied as standard - see page 3

Options

- Fail safe spring return units - clockwise or counter clockwise see pages 27-29
- Limit switch boxes for open/close indication - various switches for hazardous areas see pages 31-34
- Integral solenoid valve see page 38
- AP pneumatic positioner - full range of options see pages 41/42
- EL electropneumatic positioner - full range of options see pages 39/40
- P3 on/off positioner - full range of options including hazardous area see pages 43-45
- 180° model see page 51/52
- Female drive and mounting details to DIN 3337 and ISO 5211 see pages 57/58
- Spring to centre see page 50
- Geared manual override see page 55
- Code identification see page 30
- Torque outputs see pages 6-8
- See pages 57-60 for English dimensions and dimensions of spring options
- Accessory mount plate for positioners, switch boxes and clear cone monitor. See TD149.
- High Temperature / Low temperature options see page 5

