

Standard Coupling  
(supplied with actuator  
weight 3.7 lbs/1.7 kg)

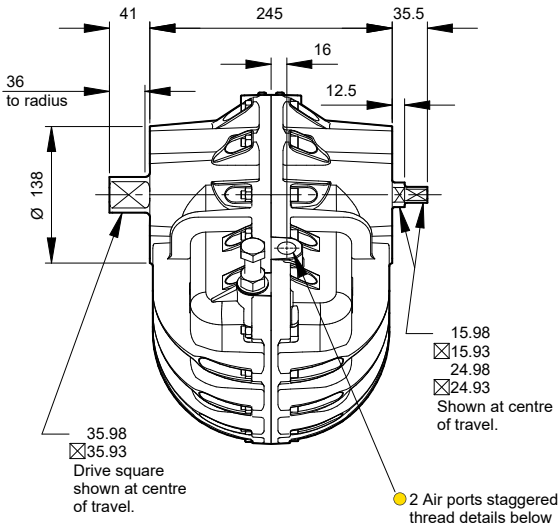

**Air Port/Mount Hole Details**

Model	Air Ports	Mount Holes & Accessory Mount Holes
154-100	G <sup>1</sup> / <sub>2</sub>	4 x M16 x 28.5 deep on 140.0 PCD 4 x M5 x 10 deep
157-100	1/2 NPT	4 x 5/8 - 11 UNC x 1.12" deep on 5.51" PCD 4 x 10-24 x 3/8" deep

Visual Red Indicator supplied as standard - see page 3

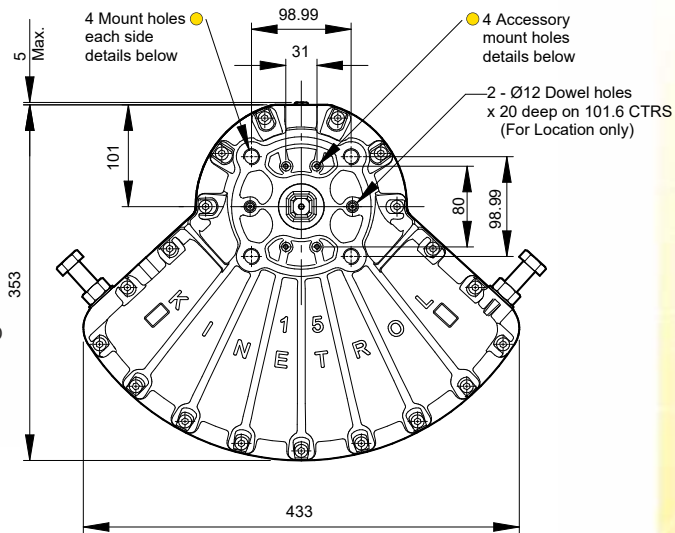

**Specification**

**Output Torque**

20337 lbf ins/2337 Nm  
at 100 psi/7 bar

**Angle of Travel (adjustable)**

80° - 100°  
(restricted travel versions available)

**Displaced Volume**

361 in<sup>3</sup>/5920 cm<sup>3</sup>

**Finish**

Epoxy stove enamel

**Weight**

46.2 lb/21.0 kg  
(excluding coupling)

For further information  
see General  
Specification on  
page 5.

**Options**

- Fail safe spring return units - clockwise or counter clockwise see pages 27-29
- Limit switch boxes for open/close indication - various switches for hazardous areas see pages 31-34
- Integral solenoid valve see page 38
- AP pneumatic positioner - full range of options see pages 41/42
- EL electropneumatic positioner - full range of options see pages 39/40
- P3 on/off positioner - full range of options including hazardous area see pages 43-45
- Code identification see page 30
- Torque outputs see pages 6-8
- See pages 57-60 for English dimensions and dimensions of spring options
- Accessory mount plate for positioners, switch boxes and clear cone monitor. See TD149.
- High temperature / low temperature options see page 5

