

Standard Coupling  
(supplied with actuator  
weight 13.3 lbs/6 kg)

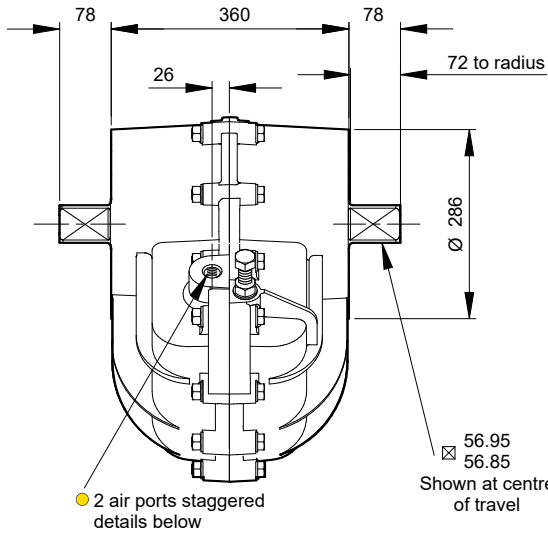

● Air Port/Mount Hole Details

Model	Air Ports	Mount Holes & Accessory Mount Holes
184-100	G <sup>3</sup> / <sub>4</sub>	4 x M30 x 50 deep on 226.3 PCD 4 x M5 x 8 deep
187-100	3/4 NPT	4 x 1 1/8 - 7 UNC x 2.00" deep on 8.91" PCD 4 x 10-24 UNC x 0.31" deep

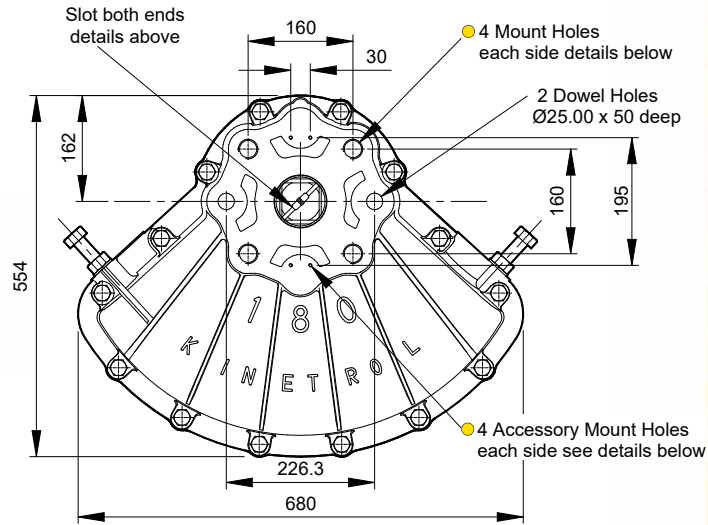

## Specification

### Output Torque

60000 lbf ins/6900 Nm  
at 100 psi/7 bar

### Angle of Travel (adjustable)

80° - 100°  
(restricted travel  
versions available)

### Displaced Volume

1047 in<sup>3</sup>/17170 cm<sup>3</sup>

### Finish

Epoxy stove enamel

### Weight

194 lb/88 kg  
(excluding coupling)

## Options

- Fail safe spring return units - clockwise or counter clockwise see pages 27-29
- Limit switch boxes for open/close indication - various switches for hazardous areas see pages 31-34
- AP pneumatic positioner - full range of options see pages 41/42
- EL electropneumatic positioner - full range of options see pages 39/40
- Female drive and mounting details to DIN 3337 and ISO 5211 see page 57/58
- Spring to centre see page 50
- Geared manual override see page 55
- Code identification see page 30
- Torque outputs see pages 6-8
- See pages 57-60 for English dimensions and dimensions of spring options
- High Temperature / Low temperature options see page 5

