

Specification

Output Torque

168000 lbf ins/19140 Nm
at 100 psi/7 bar

Angle of Travel (adjustable)

80° - 100°
(restricted travel
versions available)

Displaced Volume

3050 in³/50025 cm³

Finish

Epoxy stove enamel

Weight

601.91 lb/273 kg
(excluding coupling)

For further information
see General Specification
on page 5.



Vane Slot detail both ends

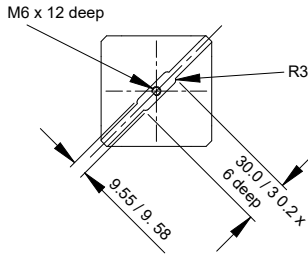

Standard Coupling
(supplied with actuator
weight 34 lbs/15.4 kg)

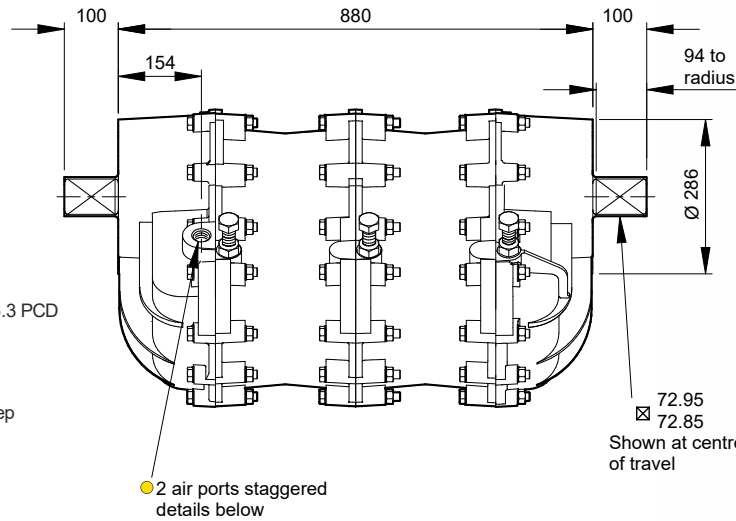
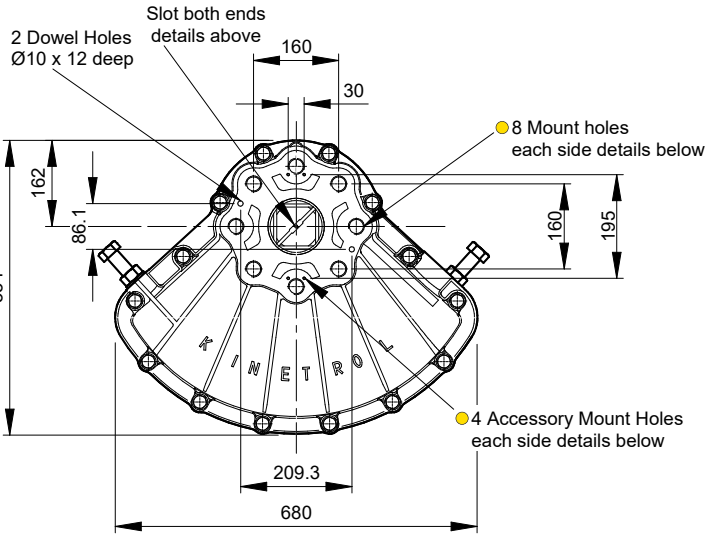
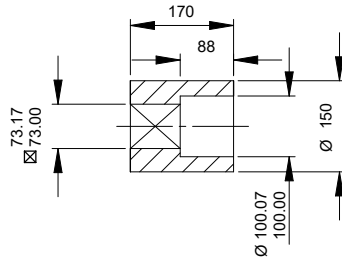

Air Ports/Mount Hole Details

Model	Air Ports	Mount Holes & Accessory Mount Holes
304-100	G1	8 x M30 x 50 deep on 226.3 PCD 4 x M5 x 8 deep
307-100	1 NPT	8 x 1 1/8 - 7 UNC x 2.00" deep on 8.91" PCD 4 x 10-24 UNC x 0.31" deep

Options

- Fail safe spring return units - clockwise or counter clockwise see pages 27-29
- Limit switch boxes for open/close indication - various switches for hazardous areas see pages 31-34
- AP pneumatic positioner - full range of options see pages 41/42
- EL electropneumatic positioner - full range of options see pages 39/40
- Code identification see page 30
- Torque outputs see pages 6-8
- See pages 57-60 for English dimensions and dimensions of spring options
- High Temperature / Low temperature options see page 5